

GENERAL NOTES: FLORIDA BUILDING CODE 2007

1- CODE: THIS PRODUCT HAS BEEN TESTED AND DESIGNED IN ACCORDANCE WITH THE FLORIDA BUILDING CODE 2007 INCLUDING THE HIGH VELOCITY HURRICANE ZONE (HVHZ).

2- DEFINITION: THIS PRODUCT IS A PROJECT-OUT TYPE WINDOW DESIGNED, CONSTRUCTED AND TESTED TO PROVIDE PROTECTION FROM HURRICANE FORCE WINDS AND WIND BORNE DEBRIS (SMALL MISSILE) WITHIN THE ALLOWABLE DESIGNED PRESSURES AND LIMITATIONS STATED IN THIS APPROVAL. INSTALLATION BELOW 30 FEET ELEVATION IT WILL REQUIRE APPROVED HURRICANE PROTECTION DEVICES.

3- POSTING:

"NR ARCHITECTURAL PRODUCTS, INC.
WEST PALM BEACH - FLORIDA
MIAMI-DADE COUNTY PRODUCT CONTROL APPROVED"

4- DESIGN LOADS: THE DESIGNED LOADS MUST BE CALCULATED BY A PROFESSIONAL ARCHITECT OR ENGINEER FOR EACH SPECIFIC PROJECT. THE CALCULATED DESIGNED PRESSURE MUST NOT EXCEED THE ALLOWABLE WINDOW PRESSURE.

5- MATERIAL: GLAZING TO BE IMPACT LAMINATED GLASS AS SPECIFIED ON THIS APPROVAL.

6- FASTENERS: ASSEMBLY SCREWS AND ANCHORS SHALL BE AS SPECIFIED IN THE CURRENT SET OF DRAWINGS. INSTALLATION AND LOADS AS PER THIS APPROVAL. ANCHOR QUANTITY & SPACING MUST NOT EXCEED THE MAXIMUM LIMITS SPECIFIED BY THIS APPROVAL.

7- USE: IT SHALL BE THE RESPONSIBILITY OF THE CONTRACTOR, ARCHITECT OR ENGINEER OF RECORD TO VERIFY THE FOLLOWING:

7.1- THE STABILITY OF THE STRUCTURE WHERE THE PRODUCT IS TO BE ATTACHED INSURING PROPER ANCHORAGE.

7.2- THE SITE SPECIFIC PROJECT CRITERIA, SUCH AS BUT NOT LIMITED TO, LOCAL CODE REQUIREMENTS, DESIGNED PRESSURES ETC.

7.3- THAT THIS APPROVAL IS ADEQUATE TO THE SPECIFIC PROJECT.

8- 33 1/3% INCREASE IN ALLOWABLE LOADS HAVE NOT BEEN USED IN THE DESIGN OF THE ANCHORS FOR THIS PRODUCT APPROVAL, HOWEVER, WOOD SCREWS WITH 1.6 INCREASE FOR WIND LOAD DURATION HAVE BEEN USED.

9- DISSIMILAR MATERIALS: MATERIALS, INCLUDING BUT NOT LIMITED TO STEEL, THAT COME IN CONTACT WITH OTHER DISSIMILAR MATERIALS SHALL MEET THE REQUIREMENTS OF 2007 FLORIDA BUILDING CODE.

FOR ALLOWABLE SIZES AND PRESSURES REFER TO:
SHEETS 2, 3 AND 4

PRODUCT NOT TO BE INSTALLED BELOW 30 FEET ELEVATION
WITHOUT HURRICANE PROTECTION DEVICES

TYPICAL ELEVATIONS

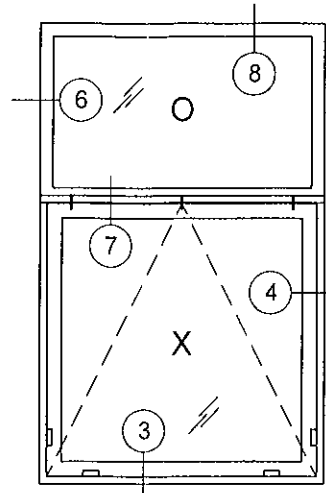

<OX> COMBINATION
FIXED / PROJECT-OUT
SEE SHEET 3 FOR RATING

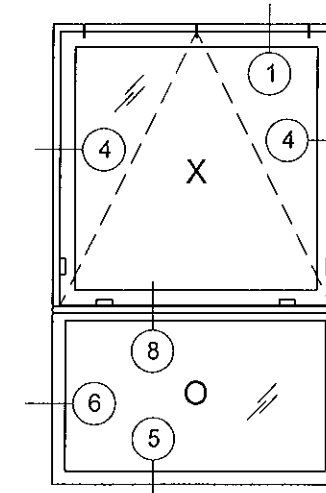

<XD> COMBINATION
PROJECT-OUT / FIXED
SEE SHEET 3 FOR RATING

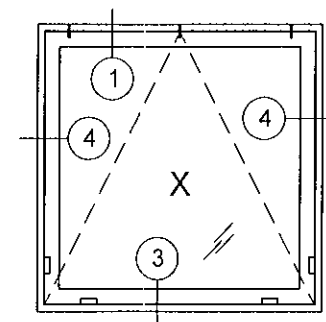

<X> SINGLE
PROJECT-OUT WINDOW
SEE SHEET 2 FOR RATING

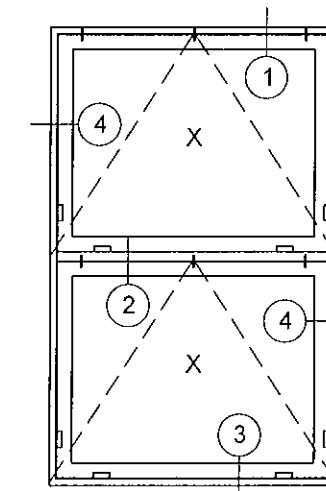

<XX> COMBINATION
PROJECT-OUT / PROJECT-OUT
SEE SHEET 4 FOR RATING

INDEX:

SHEET	DESCRIPTION
1 of 9	GENERAL NOTES, INDEX AND TYPICAL ELEVATIONS
2 of 9	TABLE 1 DESIGN RATING FOR SINGLE PROJECT-OUT UNITS
3 of 9	TABLE 2 DESIGN RATING FOR COMBINATION PROJECT-OUT / FIXED UNITS
4 of 9	TABLE 3 DESIGN RATING FOR COMBINATION PROJECT-OUT / PROJECT-OUT UNITS
5 of 9	TYPICAL DETAILS
6 of 9	ANCHORAGE LAY-OUT WITH STRAPS
7 of 9	ANCHORAGE LAY-OUT WITH SHEAR CLIP
8 of 9	WINDOW COMPONENTS AND BILL OF MATERIAL
9 of 9	HARDWARE SCHEDULE, CORNER ASSEMBLY, GLAZING DETAILS & WEEP HOLES

MANUFACTURER:

NR
ARCHITECTURAL PRODUCTS, INC.
4348 WESTROADS DRIVE
WEST PALM BEACH
FLORIDA - 33407
WWW.NRWINDOWS.COM
PH.: (561) 844-1121
FAX: (561) 844-6131

PRODUCT:
NRAP 2500-PO
PROJECT-OUT WINDOW
SMALL MISSILE IMPACT

Engineering:
EngCo Inc.
CA 8116
6971 W. Sunrise Blvd. 104
Plantation, Fl. 33313
ENGCO@AOL.COM

MAR 23 2009
Engineer Seal
Pedro De Figueiredo
PE 52609

DRAFTING:
PK DRAFTING & MORE

MIAMI-DADE BCCO:

Date: 03/23/2009
Scale: NA
Design by: PPMF

Drawing Number
09-058

SHEET
1 of 9

MANUFACTURER:
NR
 ARCHITECTURAL
 PRODUCTS, INC.
 4348 WESTROADS DRIVE
 WEST PALM BEACH
 FLORIDA - 33407
 WWW.NRWINDOWS.COM
 PH.: (561) 844-1121
 FAX: (561) 844-6131

PRODUCT:
NRAP 2500-PO
 PROJECT-OUT WINDOW
 SMALL MISSILE IMPACT

Engineering:
EngCo Inc.
 CA 8116
 6971 W. Sunrise Blvd. 104
 Plantation, FL 33313
 ENGCO@AOL.COM

MAR 23 2009

Engineer Seal
 Pedro De Figueiredo
 PE 52609

DRAFTING:
PK DRAFTING & MORE

MIAMI-DADE BCCO:

Date: 03/23/2009
 Scale: NA
 Design by: PPMF

Drawing Number
09-058

SHEET
 2 of 9

TABLE 1
 DESIGNED RATING FOR
 SINGLE PROJECT-OUT UNITS (PSF)

MAX. FRAME		GLASS TYPE G3/G4	
FW	FH	EXT (+)	INT (-)
32	32	120.0	120.0
	36	120.0	120.0
	40	120.0	120.0
	44	120.0	120.0
	48	120.0	120.0
	52	93.7	93.7
	56	65.6	65.6
	64	35.1	35.1
72	20.5	20.5	
36	32	120.0	120.0
	36	120.0	120.0
	40	120.0	120.0
	44	120.0	120.0
	48	120.0	120.0
	52	87.0	87.0
	56	60.5	60.5
	64	32.1	32.1
40	32	120.0	120.0
	36	120.0	120.0
	40	120.0	120.0
	44	120.0	120.0
	48	120.0	120.0
	52	82.4	82.4
	56	56.9	56.9
	64	32.1	32.1
44	32	120.0	120.0
	36	120.0	120.0
	40	120.0	120.0
	44	120.0	120.0
	48	120.0	120.0
	52	79.3	79.3
	56	56.9	56.9
	64	32.1	32.1
48	32	120.0	120.0
	36	120.0	120.0
	40	120.0	120.0
	44	120.0	120.0
	48	120.0	120.0
	52	104.7	104.7
	56	101.1	101.1
	64	83.5	83.5
52	32	120.0	120.0
	36	112.9	112.9
	40	108.0	108.0
	44	104.7	104.7
	48	104.7	104.7
	52	104.7	104.7
	56	101.1	101.1
	64	83.5	83.5
56	32	108.0	108.0
	36	101.1	101.1
	40	96.0	96.0
	44	96.0	96.0
	48	96.0	96.0
	52	96.0	96.0
	56	96.0	96.0
	64	83.5	83.5
64	32	90.0	90.0
	36	83.5	83.5
	40	83.5	83.5
	44	83.5	83.5
	48	83.5	83.5
	52	83.5	83.5
	56	83.5	83.5
	64	83.5	83.5
72	32	77.1	77.1
	36	77.1	77.1
	40	77.1	77.1
	44	77.1	77.1
	48	77.1	77.1
	52	77.1	77.1
	56	77.1	77.1
	64	77.1	77.1

FW- FRAME WIDTH IN INCHES
 FH- FRAME HEIGHT IN INCHES
 PRESSURES IN PSF

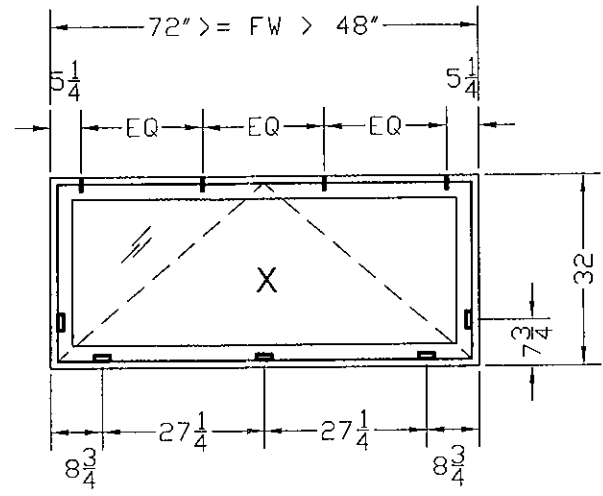

UNITS WITH WIDTH GREATER THAN 48" WILL REQUIRE:
 3 SILL LOCKS AND 4 HEADER SNUBBERS

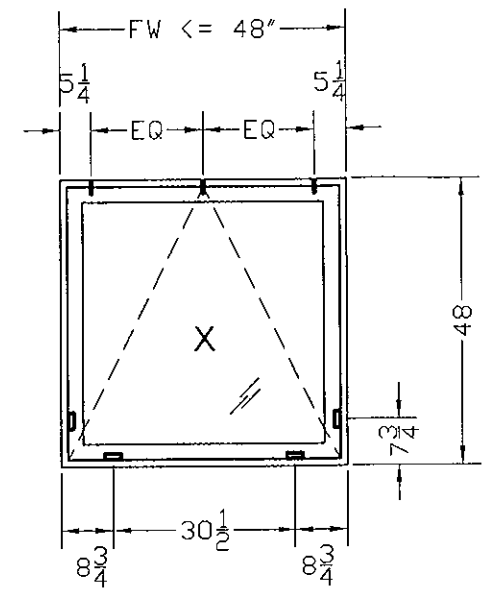

UNITS WITH WIDTH LESS OR EQUAL THAN 48" WILL REQUIRE:
 2 SILL LOCKS AND 3 HEADER SNUBBERS

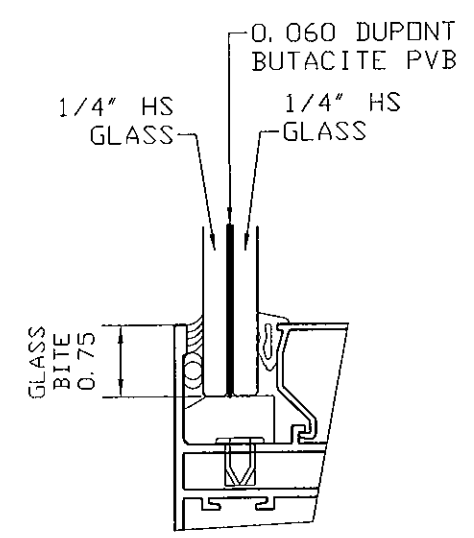

GLASS TYPE G3

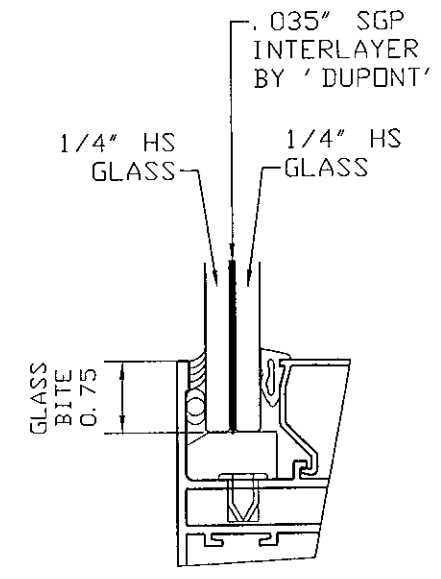

GLASS TYPE G4

TABLE 2
DESIGNED RATING FOR
COMBINATION PROJECT-OUT AND FIXED UNITS (PSF)

MAXIMUM FRAME DIMENSIONS				GLASS TYPE G3/G4	
FTW	FXH	FDH	FTH	EXT (+)	INT (-)
32	32	43.000	75.000	120.0	120.0
	36	43.000	79.000	120.0	120.0
	40	43.000	83.000	120.0	120.0
	44	43.000	87.000	120.0	120.0
	48	43.000	91.000	120.0	120.0
	52	43.000	95.000	93.7	93.7
	56	43.000	99.000	65.6	65.6
	64	43.000	107.000	35.1	35.1
72	43.000	115.000	20.5	20.5	
36	32	38.125	70.125	120.0	120.0
	36	38.125	74.125	120.0	120.0
	40	38.125	78.125	120.0	120.0
	44	38.125	82.125	120.0	120.0
	48	38.125	86.125	120.0	120.0
	52	38.125	90.125	87.0	87.0
	56	38.125	94.125	60.5	60.5
	64	38.125	102.125	32.1	32.1
40	32	34.375	66.375	120.0	120.0
	36	34.375	70.375	120.0	120.0
	40	34.375	74.375	120.0	120.0
	44	34.375	78.375	120.0	120.0
	48	34.375	82.375	120.0	120.0
	52	34.375	86.375	82.4	82.4
	56	34.375	90.375	56.9	56.9
	64	34.375	99.375	28.5	28.5
44	32	31.250	63.250	120.0	120.0
	36	31.250	67.250	120.0	120.0
	40	31.250	71.250	120.0	120.0
	44	31.250	75.250	120.0	120.0
	48	31.250	79.250	120.0	120.0
	52	31.250	83.250	79.3	79.3
	60	31.250	91.250	47.8	47.8
	72	31.250	103.250	23.9	23.9
48	32	28.625	60.625	120.0	120.0
	36	28.625	64.625	120.0	120.0
	40	28.625	68.625	120.0	120.0
	44	28.625	72.625	120.0	120.0
	48	28.625	76.625	120.0	120.0
	56	28.625	84.625	82.4	82.4
	64	28.625	92.625	56.9	56.9
	72	28.625	100.625	32.1	32.1
52	32	26.375	58.375	94.5	94.5
	36	26.375	62.375	90.8	90.8
	40	26.375	66.375	88.0	88.0
	44	26.375	70.375	86.1	86.1
56	32	24.500	56.500	70.9	70.9
	36	24.500	60.500	67.7	67.7
	40	24.500	64.500	65.3	65.3
64	32	21.500	53.500	42.6	42.6
	36	21.500	57.500	40.4	40.4
72	32	19.125	51.125	27.3	27.3

FTW- MAXIMUM FRAME TOTAL WIDTH IN INCHES
 FXH- MAXIMUM OPERABLE FRAME HEIGHT IN INCHES
 FDH- MAXIMUM FIXED FRAME HEIGHT IN INCHES
 FTH- MAXIMUM FRAME TOTAL HEIGHT IN INCHES
 PRESSURES IN PSF

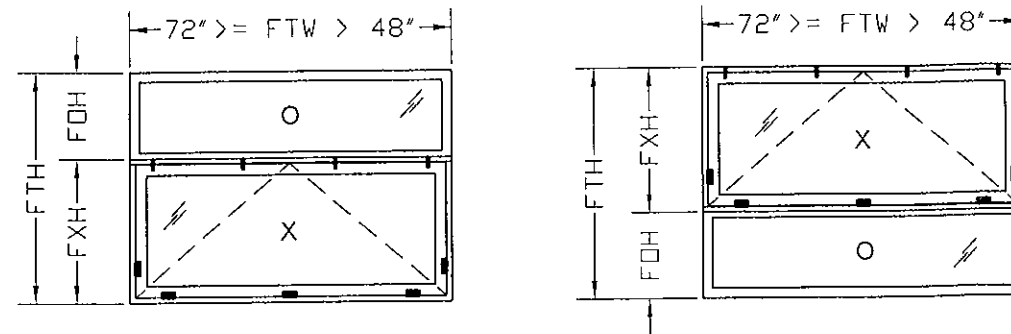

UNITS WITH FRAME WIDTH GREATER THAN 48" WILL REQUIRE:
 3 SILL LOCKS AND 4 HEADER SNUBBERS
 SEE SINGLE WINDOW FOR HARDWARE LOCATION

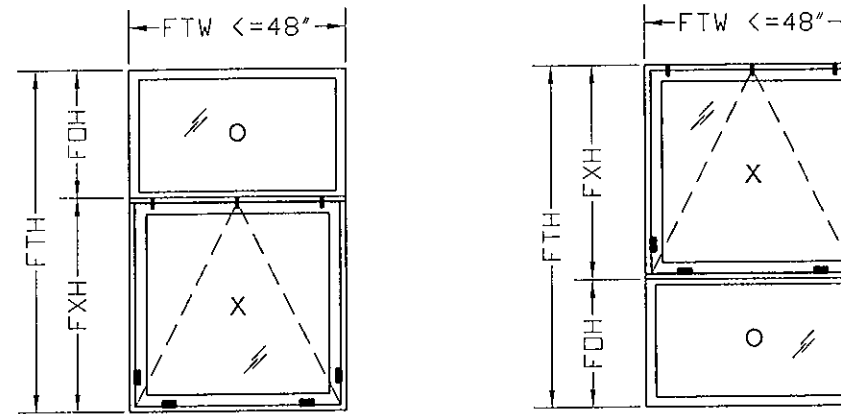

UNITS WITH WIDTH LESS OR EQUAL THAN 48" WILL REQUIRE:
 2 SILL LOCKS AND 3 HEADER SNUBBERS
 SEE SINGLE WINDOW FOR HARDWARE LOCATION

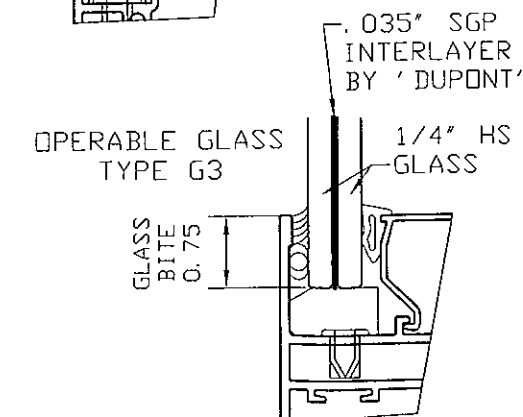
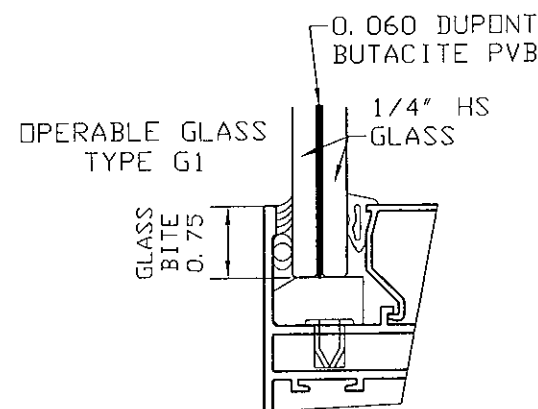
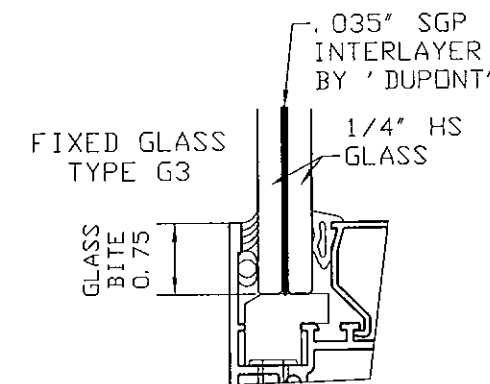
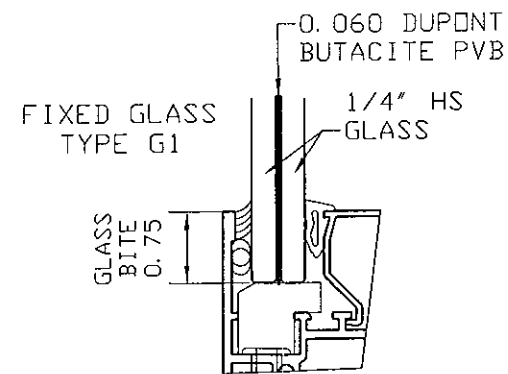

MANUFACTURER:
NR
 ARCHITECTURAL
 PRODUCTS, INC.
 4348 WESTROADS DRIVE
 WEST PALM BEACH
 FLORIDA - 33407
 WWW.NRWINDOWS.COM
 PH.: (561) 844-1121
 FAX: (561) 844-6131

PRODUCT:
NRAP 2500-PO
 PROJECT-OUT WINDOW
 SMALL MISSILE IMPACT

Engineering:
EngCo Inc.
 CA 8116
 6971 W. Sunrise Blvd. 104
 Plantation, FL 33313
 ENGCO@AOL.COM

MAR 23 2009

Engineer Seal
 Pedro De Figueiredo
 PE 52609

DRAFTING:
PK DRAFTING & MORE

MIAMI-DADE BCCO:

Date: 03/23/2009
 Scale: NA
 Design by: PPMF

Drawing Number
09-058

SHEET
 3 of 9

MANUFACTURER:

NR
ARCHITECTURAL PRODUCTS, INC.
 4348 WESTROADS DRIVE
 WEST PALM BEACH
 FLORIDA - 33407
 WWW.NRWINDOWS.COM
 PH.: (561) 844-1121
 FAX: (561) 844-6131

PRODUCT:
NRAP 2500-PO
 PROJECT-OUT WINDOW
 SMALL MISSILE IMPACT

Engineering:
EngCo Inc.
 CA 8116
 6971 W. Sunrise Blvd. 104
 Plantation, FL 33313
 ENGCO@AOL.COM

MAR 23 2009

Engineer Seal
 Pedro De Figueiredo
 PE 52609

DRAFTING:
PK DRAFTING & MORE

MIAMI-DADE BCCO:

Date: 03/23/2009
 Scale: NA
 Design by: PPMF

Drawing Number
09-058

SHEET
 4 of 9

TABLE 3
 DESIGNED RATING FOR
 COMBINATION PROJECT-OUT AND PROJECT-OUT UNITS (PSF)

MAXIMUM FRAME DIMENSIONS				GLASS TYPE G3/G4	
FTW	FX1	FX2	FTH	EXT (+)	INT (-)
32	48.0	48.0	96.0	120.0	120.0
	54.0	54.0	108.0	78.1	78.1
	57.5	57.5	114.9	58.0	58.0
	60.0	54.9	114.9	47.3	47.3
	64.0	50.9	114.9	35.1	35.1
	68.0	46.9	114.9	26.5	26.5
72.0	42.9	114.9	20.5	20.5	
36	48.0	48.0	96.0	120.0	120.0
	51.1	51.1	102.2	95.1	95.1
	52.0	50.2	102.2	87.0	87.0
	56.0	46.2	102.2	60.5	60.5
	60.0	42.2	102.2	43.5	43.5
	64.0	38.2	102.2	32.1	32.1
40	46.0	46.0	92.0	120.0	120.0
	48.0	44.0	92.0	120.0	120.0
	52.0	40.0	92.0	82.4	82.4
	56.0	36.0	92.0	56.9	56.9
	57.6	34.4	92.0	49.5	49.5
44	41.8	41.8	83.6	120.0	120.0
	44.0	39.6	83.6	120.0	120.0
	48.0	35.6	83.6	120.0	120.0
	52.4	31.2	83.6	76.5	76.5
48	38.3	38.3	76.6	120.0	120.0
	44.0	32.6	76.6	120.0	120.0
	48.0	28.6	76.6	120.0	120.0
52	35.4	35.4	70.7	87.2	87.2
	38.0	32.7	70.7	87.5	87.5
	40.0	30.7	70.7	88.1	88.1
	44.0	26.7	70.7	90.3	90.3
56	32.8	32.8	65.7	66.3	66.3
	36.0	29.7	65.7	66.6	66.6
	41.0	24.7	65.7	68.1	68.1
64	28.7	28.7	57.5	41.8	41.8
	36.0	21.5	57.5	42.5	42.5
72	25.5	25.5	51.1	28.5	28.5

FTW- MAXIMUM FRAME TOTAL WIDTH IN INCHES
 FX1- MAXIMUM OPERABLE 1 FRAME HEIGHT IN INCHES
 FX2- MAXIMUM OPERABLE 2 FRAME HEIGHT IN INCHES
 FTH- MAXIMUM FRAME TOTAL HEIGHT IN INCHES
 PRESSURES IN PSF

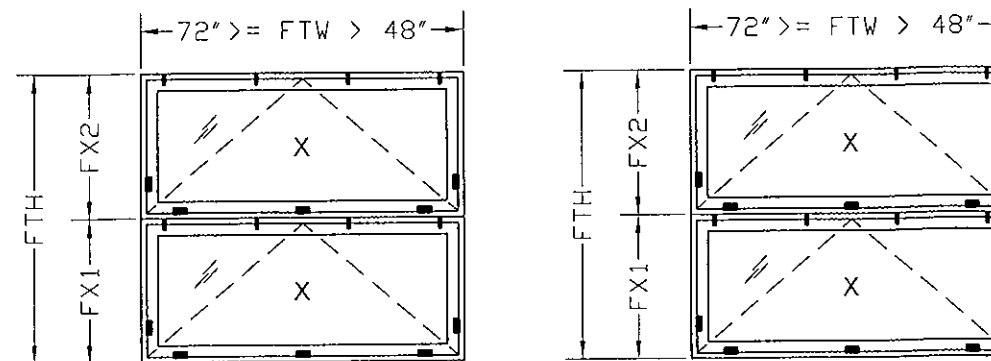

UNITS WITH FRAME WIDTH GREATER THAN 48" WILL REQUIRE:
 3 SILL LOCKS AND 4 HEADER SNUBBERS
 SEE SINGLE WINDOW FOR HARDWARE LOCATION

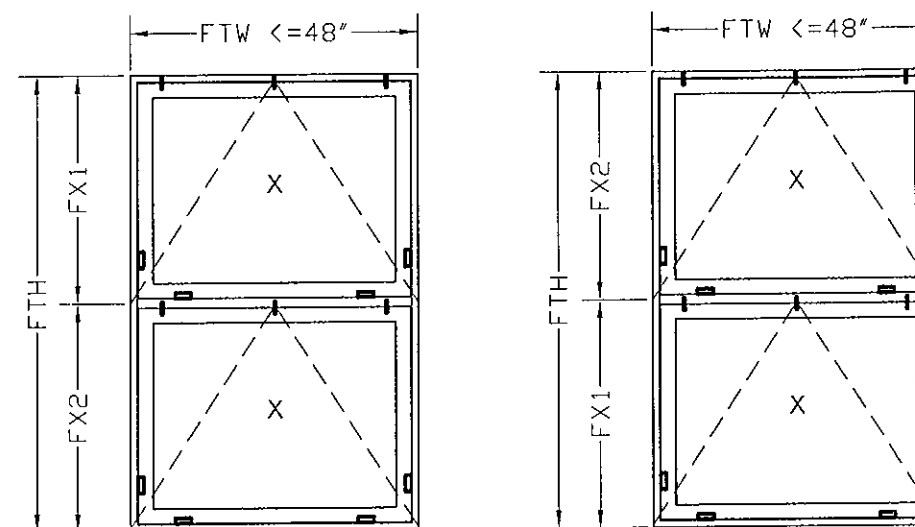

UNITS WITH WIDTH LESS OR EQUAL THAN 48" WILL REQUIRE:
 2 SILL LOCKS AND 3 HEADER SNUBBERS
 SEE SINGLE WINDOW FOR HARDWARE LOCATION

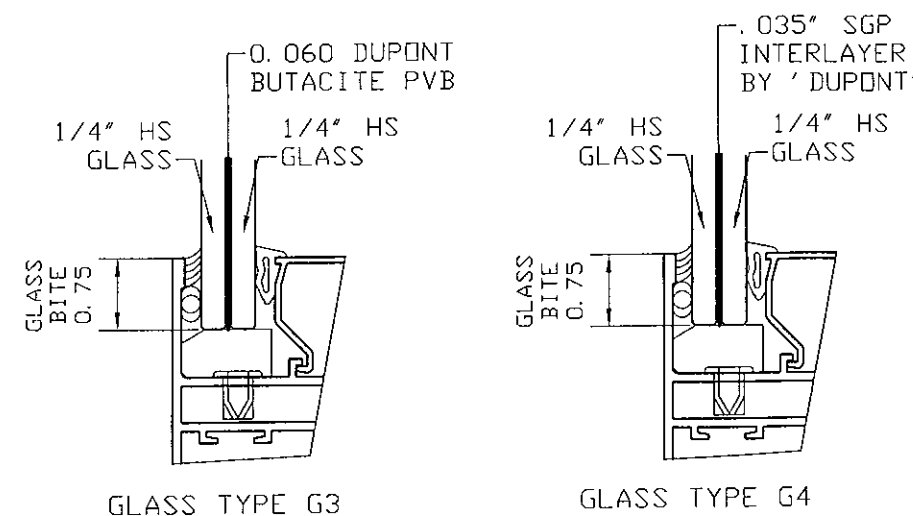

GLASS TYPE G3

GLASS TYPE G4

TYPICAL DETAILS

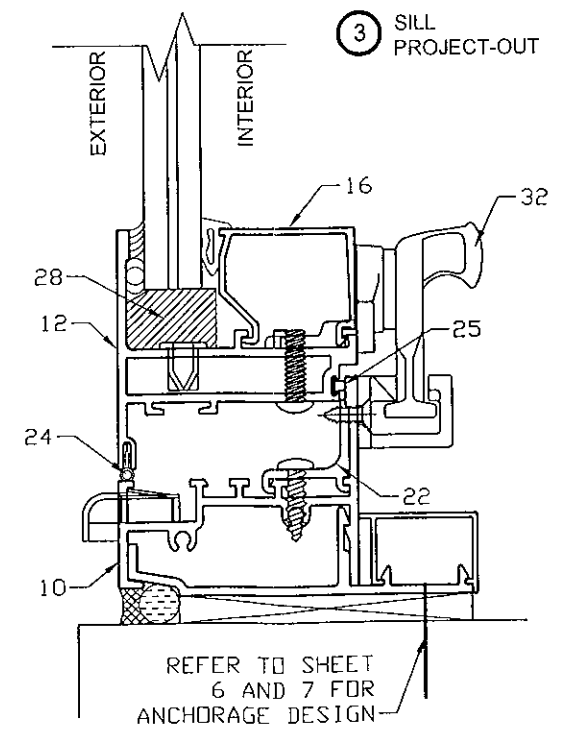
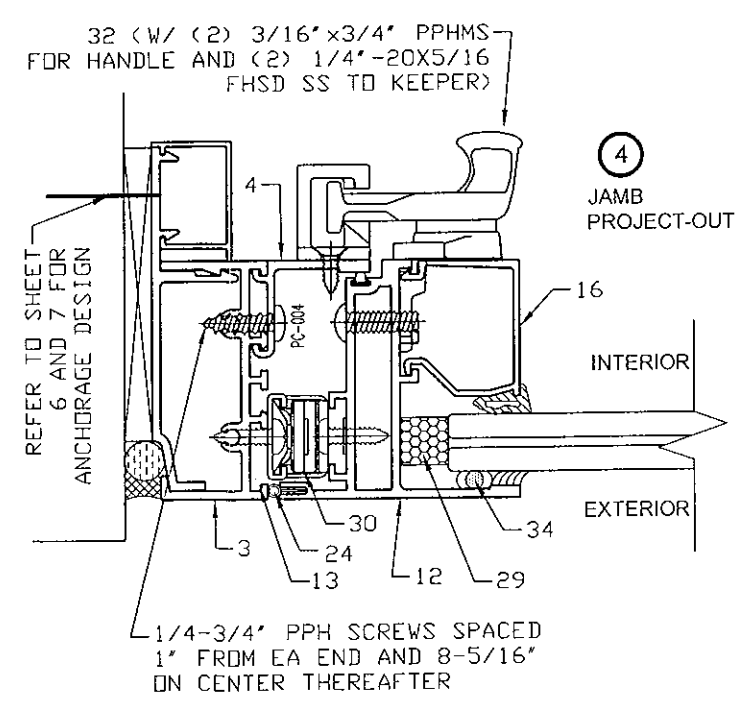
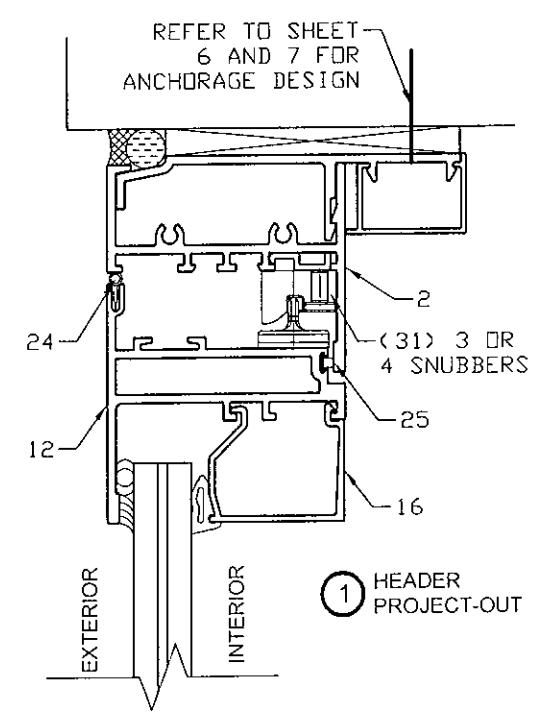
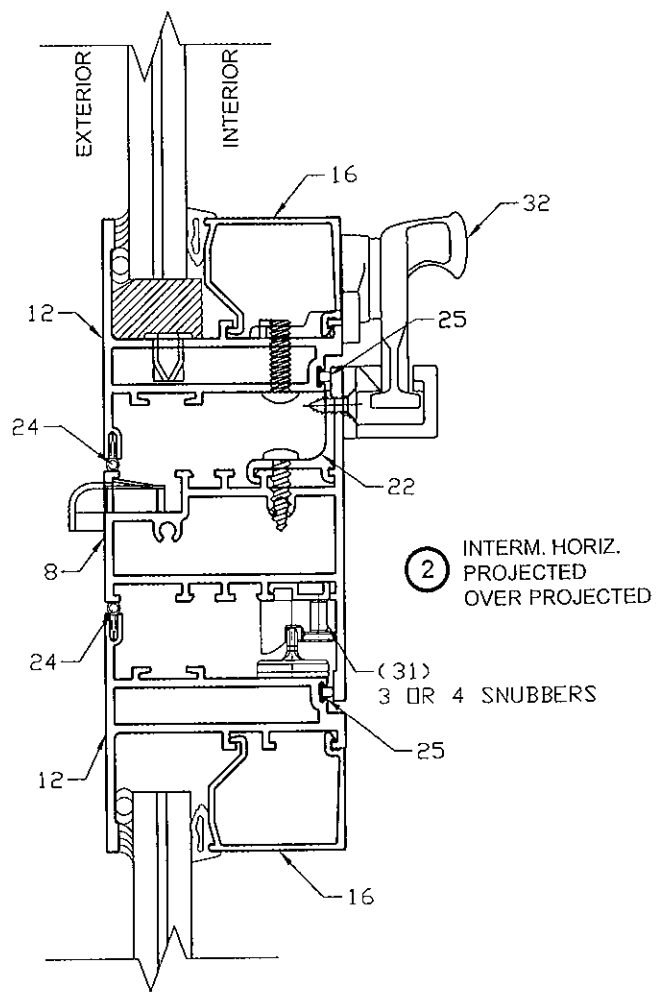
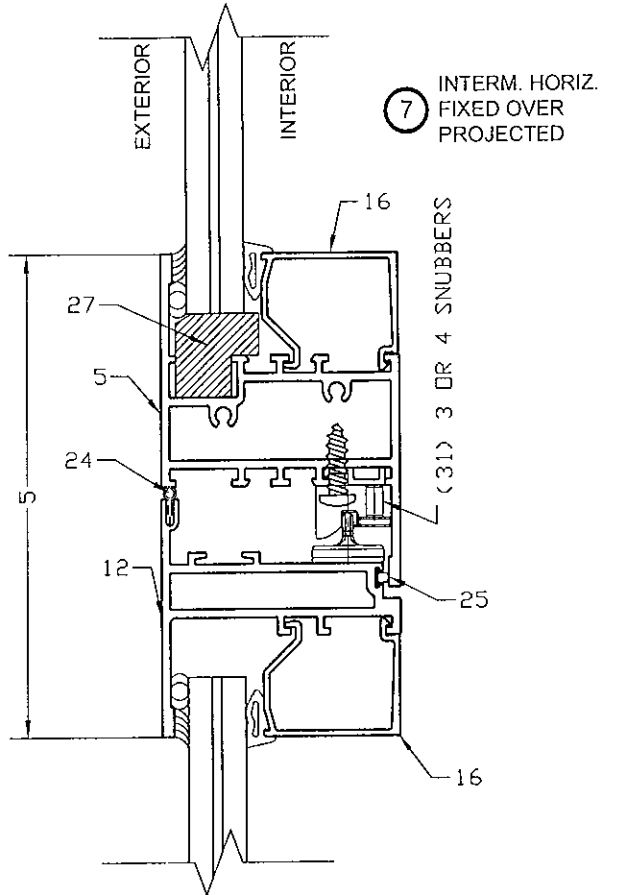
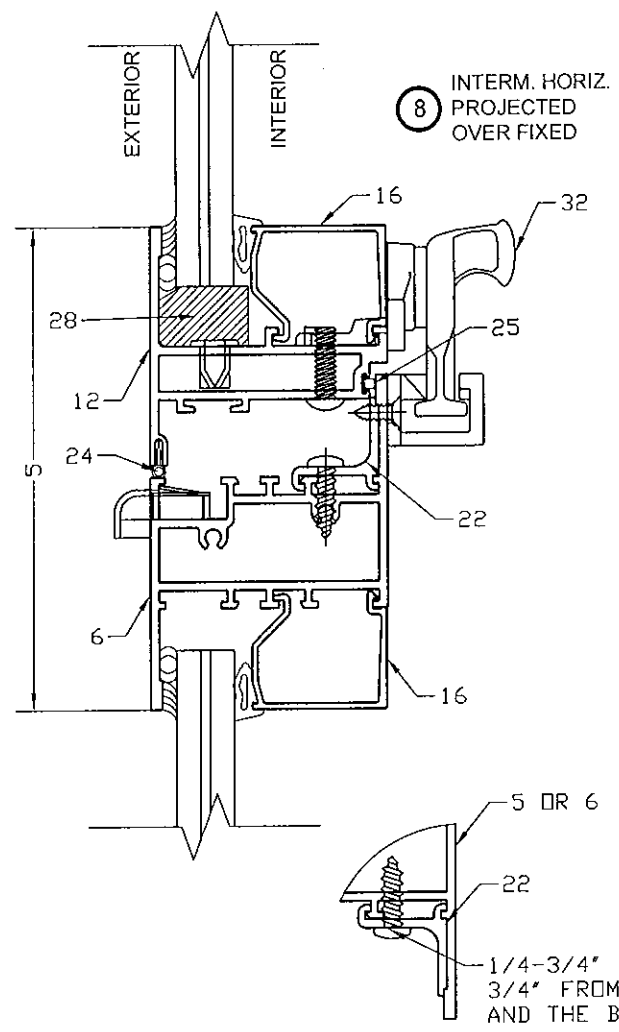
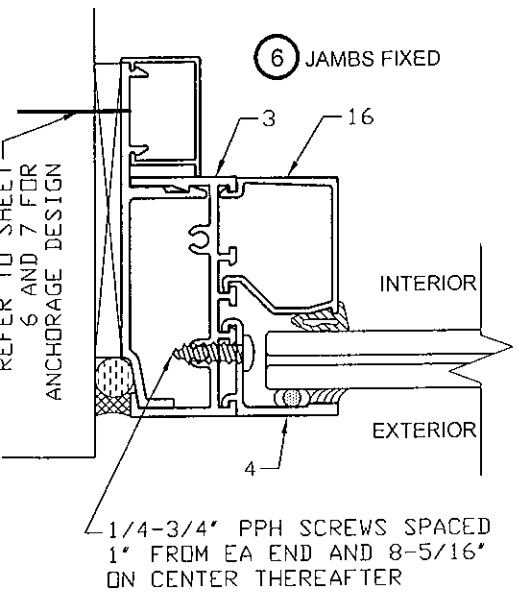
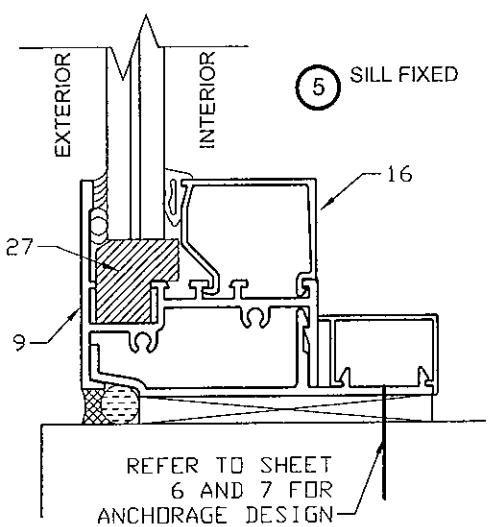
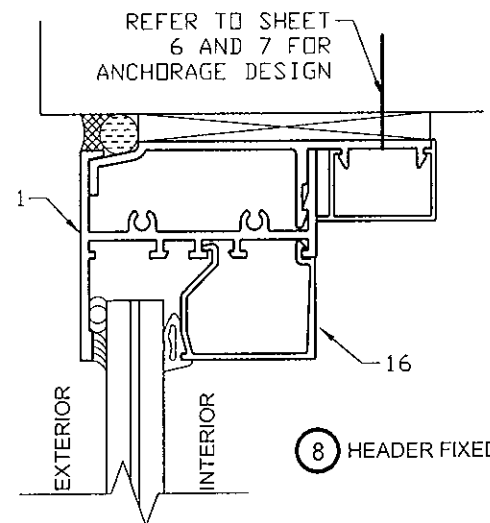

MANUFACTURER:
NR
 ARCHITECTURAL PRODUCTS, INC.
 4348 WESTROADS DRIVE
 WEST PALM BEACH
 FLORIDA - 33407
 WWW.NRWINDOWS.COM
 PH.: (561) 844-1121
 FAX: (561) 844-6131

PRODUCT:
NRAP 2500-PO
 PROJECT-OUT WINDOW
 SMALL MISSILE IMPACT

Engineering:
EngCo Inc.
 CA 8116
 6971 W. Sunrise Blvd. 104
 Plantation, FL 33313
 ENGCO@AOL.COM

MAR 23 2009
 Engineer Seal
 Pedro De Figueiredo
 PE 52609

DRAFTING:
PK DRAFTING & MORE

MIAMI-DADE BCCO:

Date: 03/23/2009
 Scale: NA
 Design by: PPMF

Drawing Number
09-058

SHEET
5 of 9

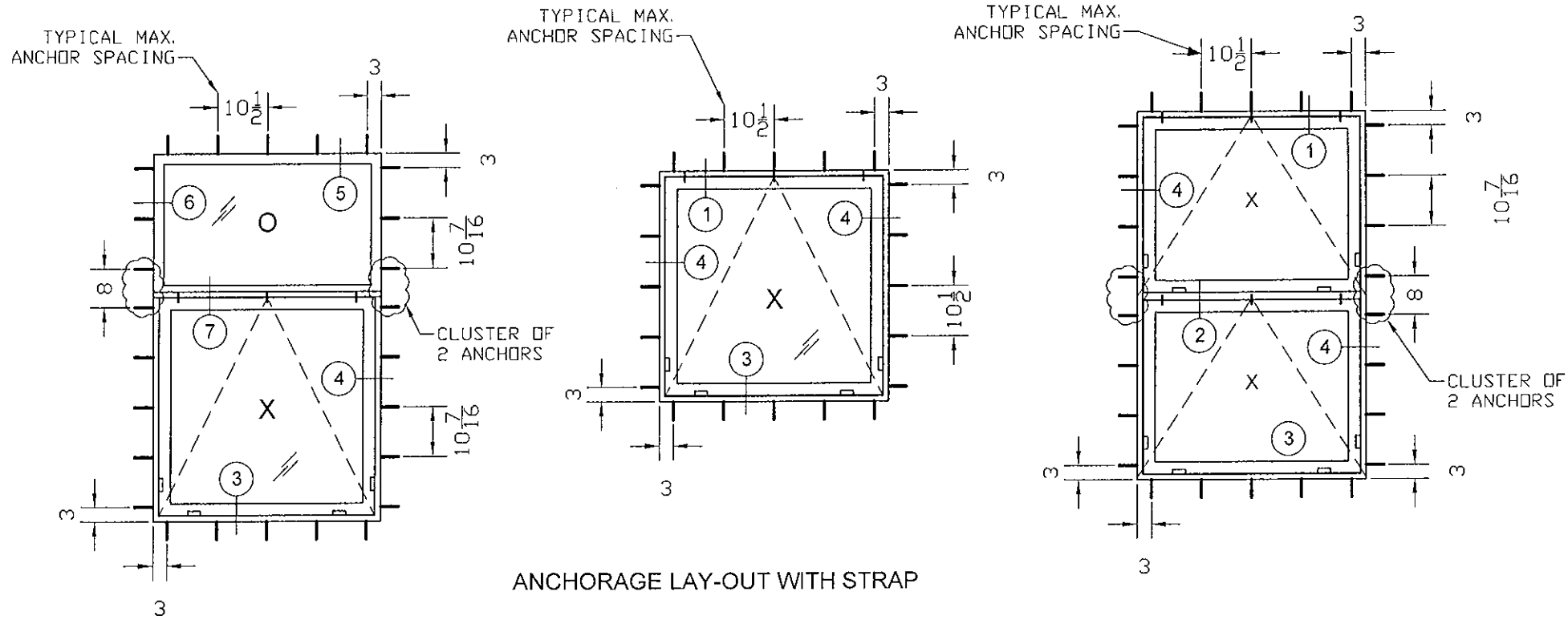

ANCHORAGE LAY-OUT WITH STRAP

TYPE	DESCRIPTION	PENETRATION	EDGE DIST.	SUBSTRATUM
A	1/4" TAPCONS	1 1/4"	2-1/2"	MASONRY OR CONCRETE
B	1/4" TAPCONS	1 1/2"	3/4"	INTO 2X BUCK (G>=0.55)
C	1/4"-14 SDS	1/8"	1/2"	6063-T6 ALUMINUM ASTM A36 STEEL

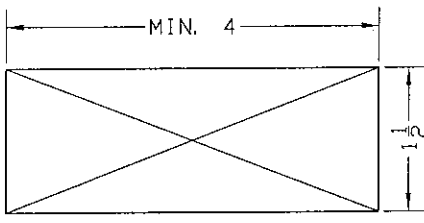
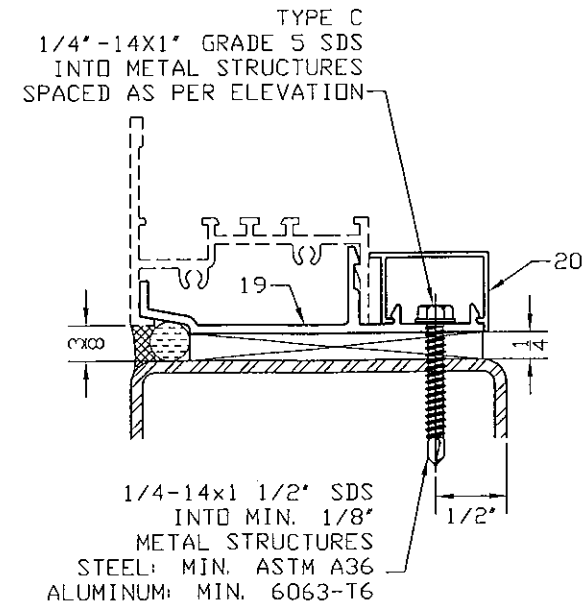
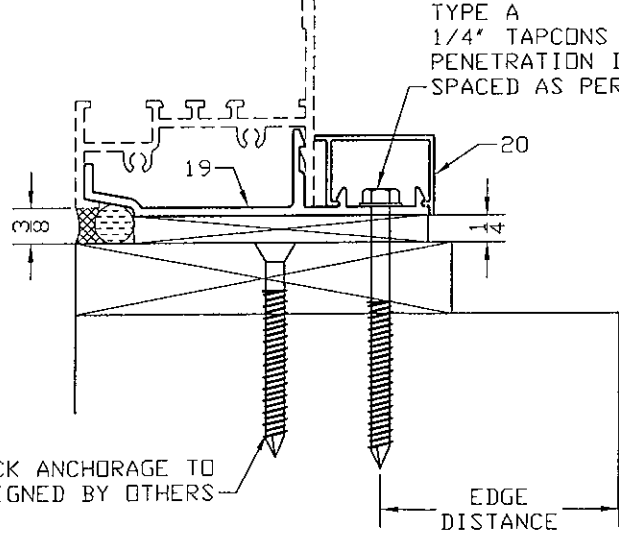
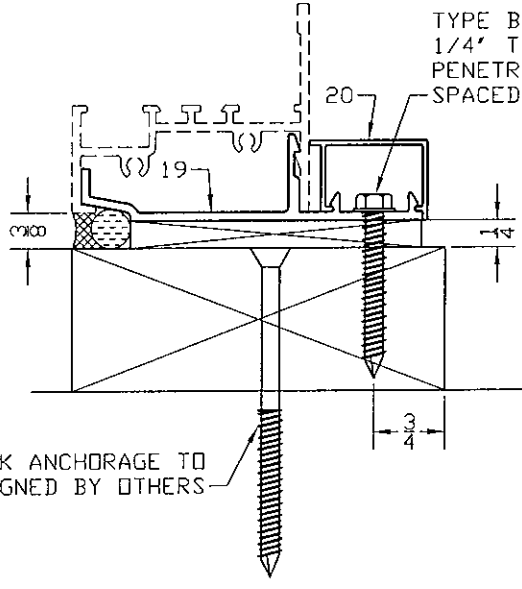
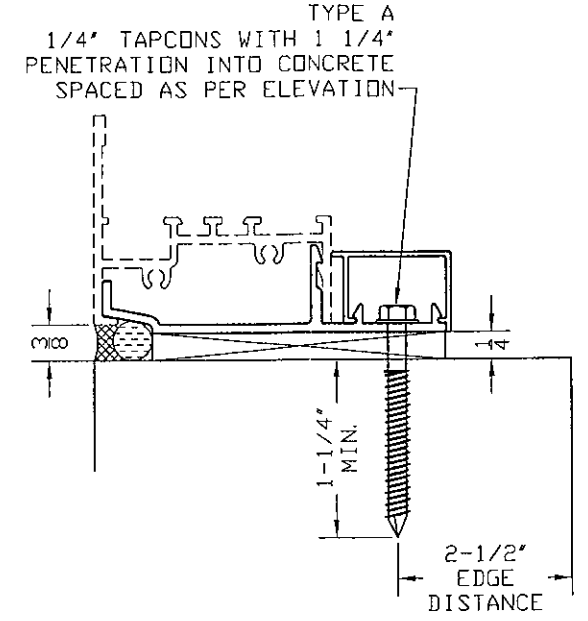

2X PRESSURE TREATED SOUTHERN PINE G>= .55

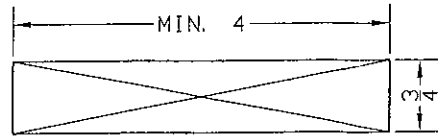

1X PRESSURE TREATED SOUTHERN PINE G>= .55

MANUFACTURER:
NR
ARCHITECTURAL PRODUCTS, INC.
4348 WESTROADS DRIVE
WEST PALM BEACH
FLORIDA - 33407
WWW.NRWINDOWS.COM
PH.: (561) 844-1121
FAX: (561) 844-6131

PRODUCT:
NRAP 2500-PO
PROJECT-OUT WINDOW
SMALL MISSILE IMPACT

Engineering:
EngCo Inc.
CA 8116
6971 W. Sunrise Blvd. 104
Plantation, Fl. 33313
ENGCO@AOL.COM

MAR 23 2009

Engineer Seal
Pedro De Figueiredo
PE 52609

DRAFTING:
PK DRAFTING & MORE

MIAMI-DADE BCCO:

Date: 03/23/2009
Scale: NA
Design by: PPMF

Drawing Number
09-058

SHEET
6 of 9

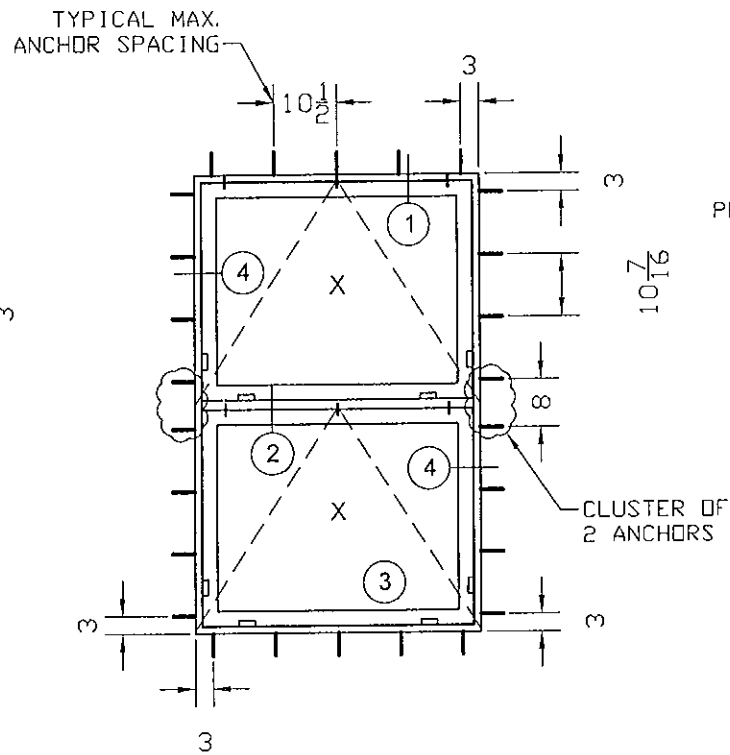
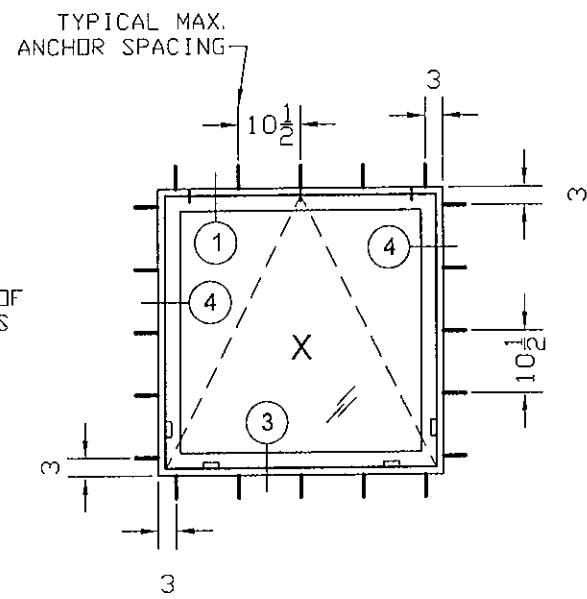
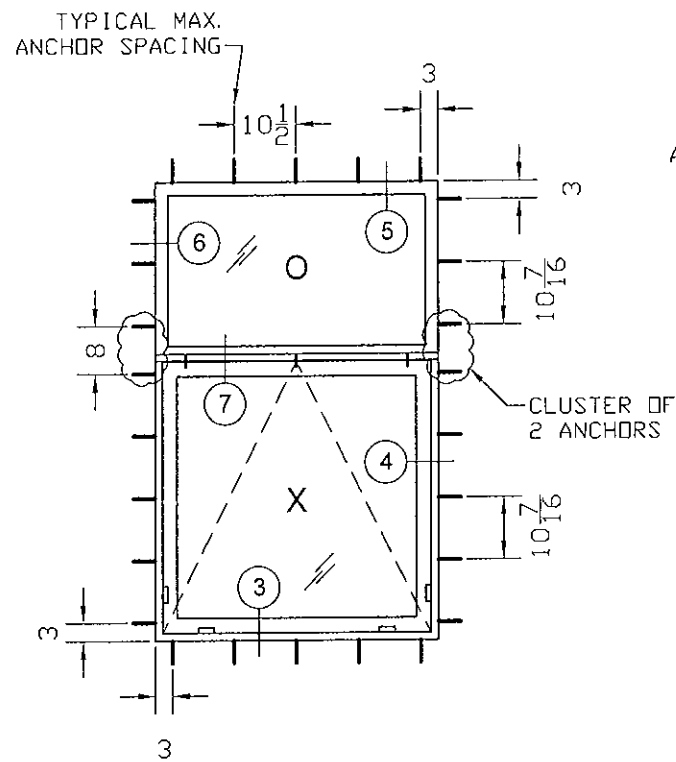

1/4" TAPCONS WITH 1 1/4" PENETRATION INTO CONCRETE SPACED AS PER ELEVATION

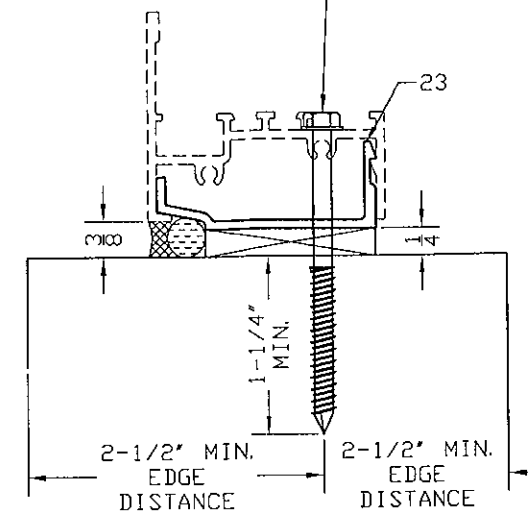

ANCHORAGE LAY-OUT WITH SHEAR CLIP

TYPE	DESCRIPTION	PENETRATION	EDGE DIST.	SUBSTRATUM
A	1/4" TAPCONS	1 1/4"	2-1/2"	MASONRY DR CONCRETE
B	1/4" TAPCONS	1 1/2"	3/4"	INTO 2X BUCK (G>=0.55)
C	1/4"-14 SDS	1/8"	1/2"	6063-T6 ALUMINUM ASTM A36 STEEL

1/4" TAPCONS WITH 1 1/2" PENETRATION INTO 2X BUCK SPACED AS PER ELEVATION

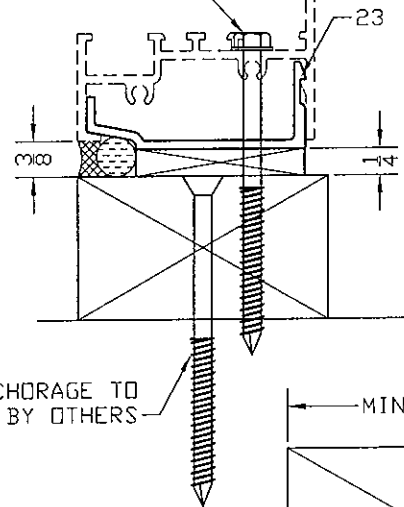

2X BUCK ANCHORAGE TO BE DESIGNED BY OTHERS

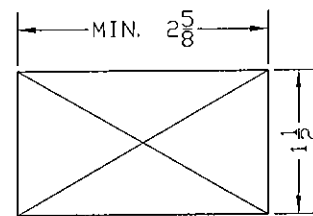

2X PRESSURE TREATED SOUTHERN PINE G>= .55

1/4" TAPCONS WITH 1 1/4" PENETRATION INTO CONCRETE SPACED AS PER ELEVATION

1X BUCK ANCHORAGE TO BE DESIGNED BY OTHERS

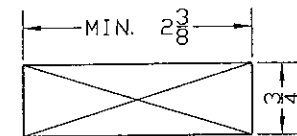
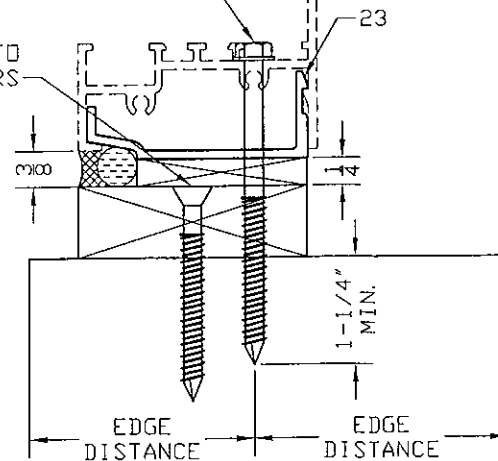

1X PRESSURE TREATED SOUTHERN PINE G>= .55

1/4"-14X2" SELF DRILLING SCREWS INTO METAL STRUCTURES SPACED AS PER ELEVATION

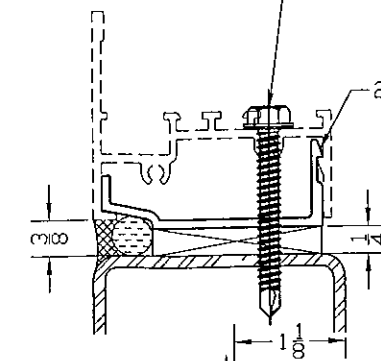

1/4"-14x1 1/2" SDS INTO MIN. 1/8" METAL STRUCTURES
STEEL: MIN. ASTM A36
ALUMINUM: MIN. 6063-T6

MANUFACTURER:

NR

ARCHITECTURAL PRODUCTS, INC.

4348 WESTROADS DRIVE
WEST PALM BEACH
FLORIDA - 33407
WWW.NRWINDOWS.COM
PH.: (561) 844-1121
FAX: (561) 844-6131

PRODUCT:

NRAP 2500-PO
PROJECT-OUT WINDOW
SMALL MISSILE IMPACT

Engineering:

EngCo Inc.

CA 8116
6971 W. Sunrise Blvd. 104
Plantation, Fl. 33313
ENGCO@AOL.COM

MAR 23 2009

Engineer Seal
Pedro De Figueiredo
PE 52609

DRAFTING:

PK DRAFTING & MORE

MIAMI-DADE BCCO:

Date: 03/23/2009
Scale: NA
Design by: PPMF

Drawing Number
09-058

SHEET
7 of 9

WINDOW COMPONENTS

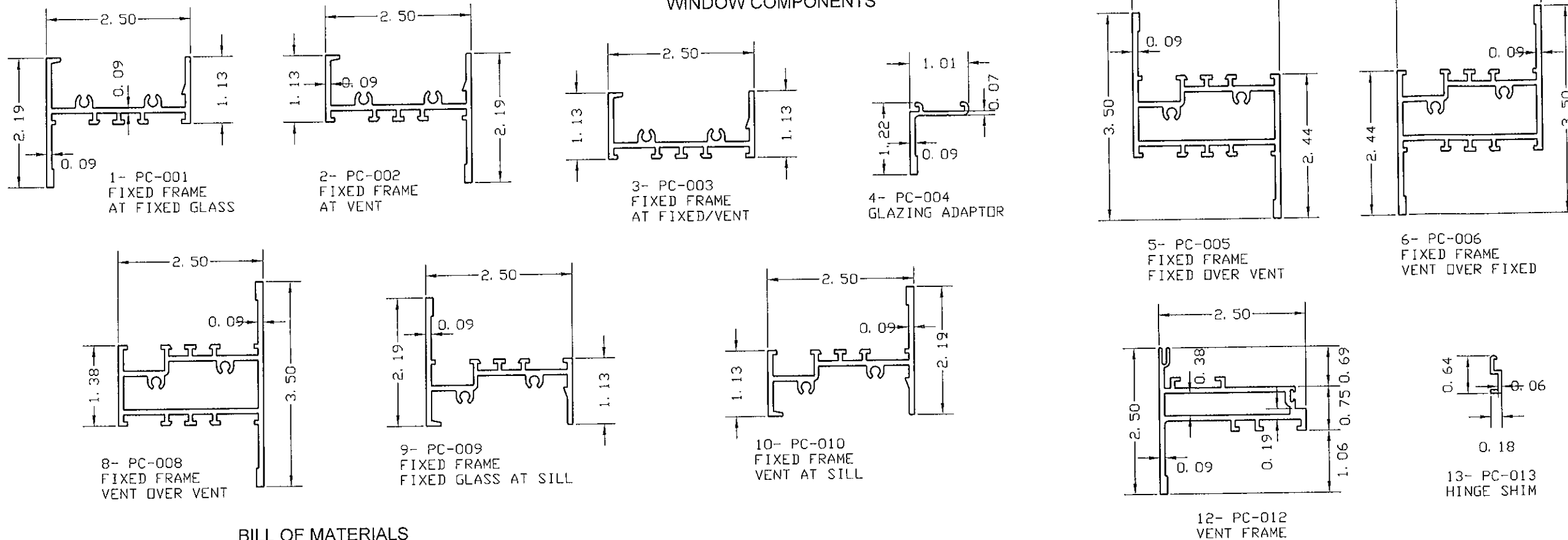

BILL OF MATERIALS

ITEM #	PART #	QUANTITY	DESCRIPTION	MATERIAL	MANF./SUPPLIER/REMARKS
1	PC-001	1	FIXED FRAME AT FIXED GLASS	ALUM	--
2	PC-002	1	FIXED FRAME AT VENT	ALUM	--
3	PC-003	1	FIXED FRAME AT FIXED/VENT	ALUM	--
4	PC-004	2/ PANEL	GLAZING ADAPTOR	ALUM	--
5	PC-005	2/ PANEL	FIXED FRAME OVER FIXED VENT	ALUM	--
6	PC-006	AS REQD.	FIXED FRAME VENT OVER FIXED	ALUM	--
8	PC-008	AS REQD.	FIXED FRAME VENT OVER VENT	ALUM	--
9	PC-009	AS REQD.	FIXED FRAME FIXED GLASS AT SILL	ALUM	--
10	PC-010	AS REQD.	FIXED FRAME VENT AT SILL	ALUM	--
12	PC-012	AS REQD.	VENT FRAME PROJECTED	ALUM	--
13	PC-013	1 / PANEL	HINGE SHIM	ALUM	--
16	PC-016	AS REQD.	GLASS STOP	ALUM	--
17	PC-017	4 PER VENT	CORNER KEY	ALUM	--
18	PC-018	AS REQD.	STRAP ANCHOR	ALUM	--
19	PC-019	AS REQD.	STRAP ANCHOR (CONCEALED)	ALUM	--
20	PC-020	AS REQD.	STRAP COVER	ALUM	--
22	PC-022	AS REQD.	REINFORCEMENT CLIP	ALUM	--
22	PC-023	AS REQD.	CONCEALED ANCHOR SHIM PLATE	ALUM	--
23	NR-G20	AS REQD.	INTERNAL POLY-WEDGE GASKET PS1126E	70 DURO EPDM	TREMCO
24	NR-G21	AS REQD.	EXTERNAL WEATHERSEAL AP150	EXTRUDED TPE	SCHLEAGAL
25	NR-G22	AS REQD.	INTERNAL WEATHERSEAL TLOCK 150	POLYETHELENE	SCHLEAGAL
26	NR-G23	-	WEEP VALVES VL 1026-107	SLICONE	VERNAV
27	NR-G24	-	FIXED GLASS SETTING BLOCK TR-1621E	EPDM	TREMCO
28	NR-G25	-	GLASS SETTING BLOCK TR-1365E	70 DURO EPDM	TREMCO
29	NR-G26	-	FIXED GLASS SETTING BLOCK TR-0214E	70 DURO EPDM	TREMCO
30	NR-A20	-	20" 4-BAR INLINE HINGE S-2000 220	ALUM	ADVANTAGE MFG. CORP
31	NR-A21	-	SNUBBER 616-625/062	SS	ADVANTAGE MFG. CORP
32	NR-A22	-	CAMLOCK 4004/420	BRONZE	BRONZE CRAFT
33	NR-A23	-	WEEP SLOT COVER	PLASTIC	NR ARCHITECTURAL PRODUCTS
34	NR-A24	-	PVC SPACER VK2526	PVC	CAPITAL TAPE
35	NR-F12	-	BASE FRAME FIXING SCREW	SS	#12 X 3/4" PPH TS
36	NR-F13	-	ADAPTOR FIXING SCREW	SS	#12 X 3/4" PPH TS

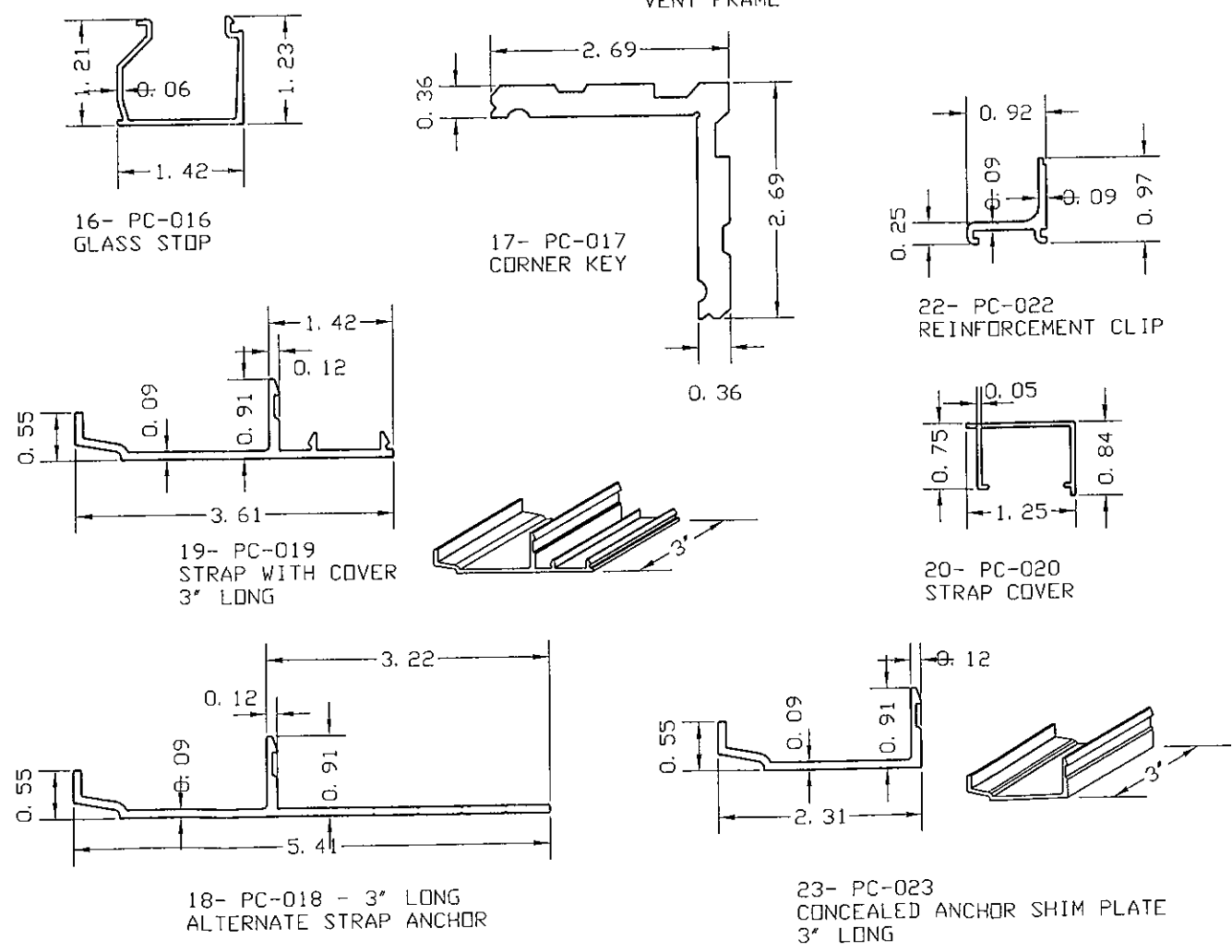

MANUFACTURER:
NR
 ARCHITECTURAL PRODUCTS, INC.
 4348 WESTROADS DRIVE
 WEST PALM BEACH
 FLORIDA - 33407
 WWW.NRWINDOWS.COM
 PH.: (561) 844-1121
 FAX: (561) 844-6131

PRODUCT:
NRAP 2500-PO
 PROJECT-OUT WINDOW
 SMALL MISSILE IMPACT

Engineering:
EngCo Inc.
 CA 8116
 6971 W. Sunrise Blvd. 104
 Plantation, Fl. 38313
 ENGCO@AOL.COM

MAR 23 2009
 Engineer Seal
 Pedro De Figueiredo
 PE 52609

DRAFTING:
PK DRAFTING & MORE

MIAMI-DADE BCCO:

Date: 03/23/2009
 Scale: NA
 Design by: PPMF

Drawing Number
09-058

SHEET
8 of 9

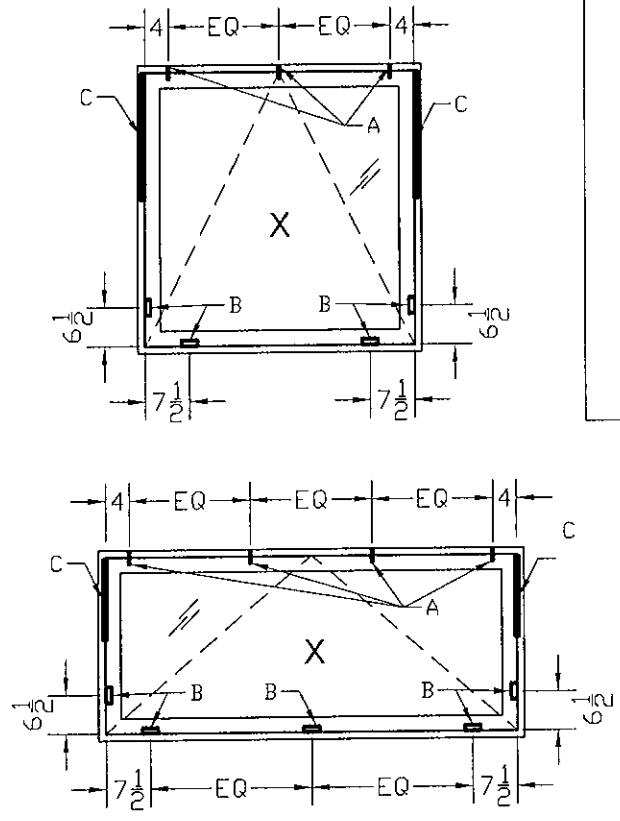

GLAZING DETAIL

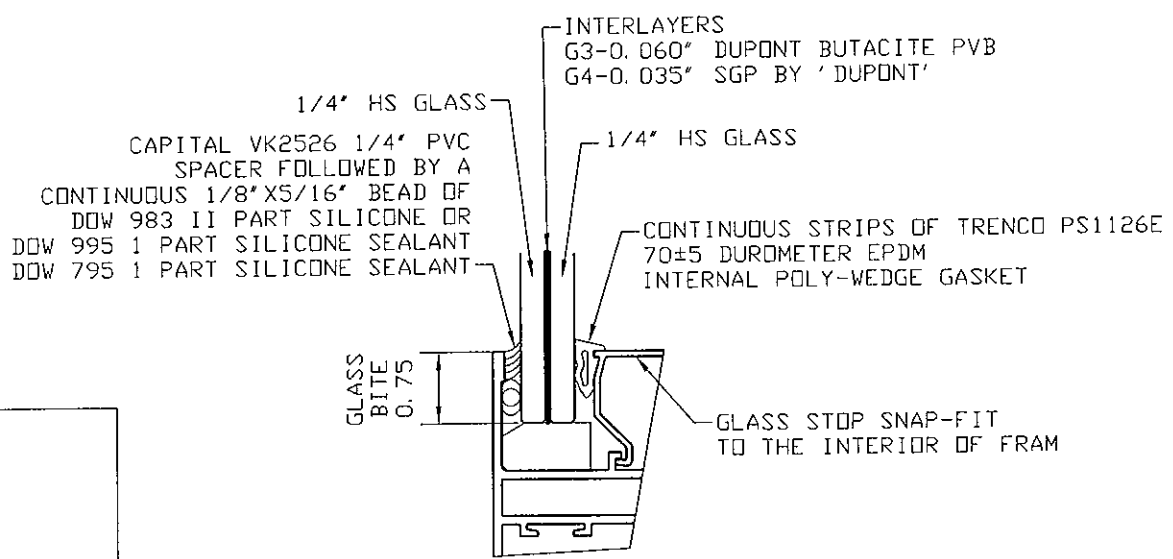

CORNER ASSEMBLY

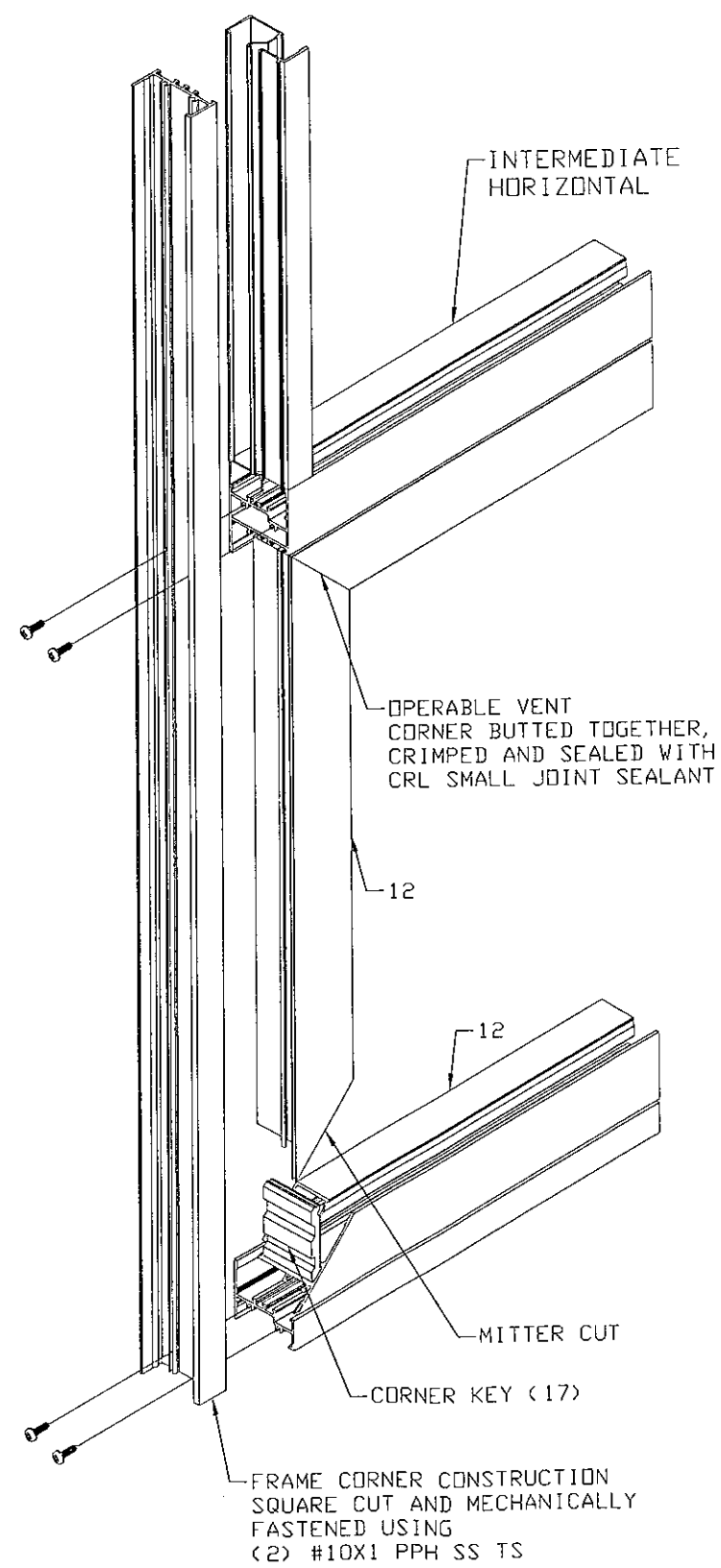

WEEP HOLES, WATER DIVERTERS AND COVERS

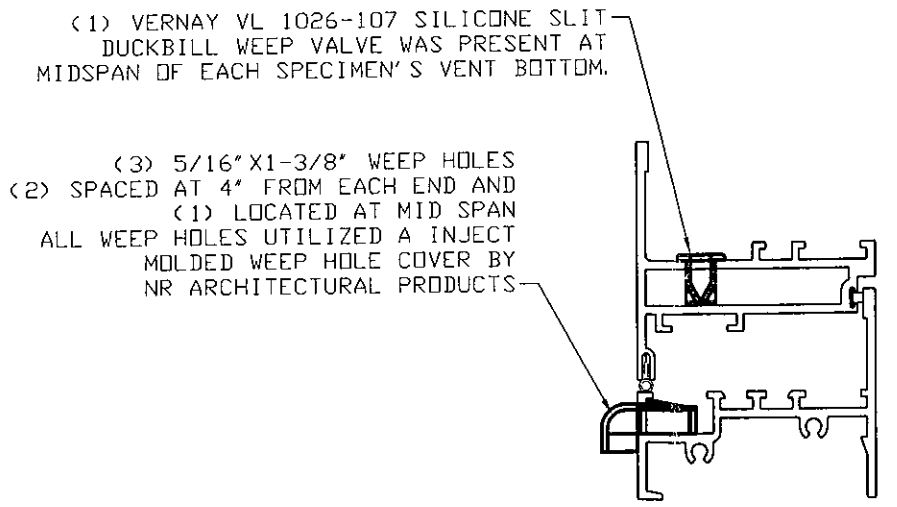

HARDWARE SCHEDULE:

A- AMC SNUBBER ASSEMBLY CONSISTING OF A DRIVER AND RECEIVER. 3 OR 4 SNUBBERS ASSEMBLIES WERE LOCATED AT VENT HEADER, 4" FROM EACH END AND THE OTHERS EQUALLY SPACED. THE RECEIVER WAS ATTACHED TO THE FRAME BASE USING (3) #10X3/4" PPH SELF TAPPING SS SCREWS AT EACH LOCATION. THE DRIVER WAS ATTACHED TO THE OPERABLE VENT USING (2) #10X3/4" PPH SELF TAPPING SS SCREWS AT EACH LOCATION.

B- BRONZECRAFT CAMLOCK ASSEMBLY CONSISTING OF THE HANDLE AND KEEPER. 1 LOCK PER JAMB LOCATED 6-1/2" FROM THE SILL AND 2 OR 3 LOCKS PER SILL LOCATED 7-1/2" FROM THE JAMBS AND ONE AT MIDDLE WHEN REQUIRED

C- AMC 220 20" SERIES 2000 4-BAR INLINE HINGES ATTACHED USING #10X5/8" PPH SELF TAPPING SCREWS; FOUR PER OPERABLE VENT AND EIGHT PER BASE FRAME

MANUFACTURER:
NR
 ARCHITECTURAL PRODUCTS, INC.
 4348 WESTROADS DRIVE
 WEST PALM BEACH
 FLORIDA - 33407
 WWW.NRWINDOWS.COM
 PH.: (561) 844-1121
 FAX: (561) 844-6131

PRODUCT:
NRAP 2500-PO
 PROJECT-OUT WINDOW
 SMALL MISSILE IMPACT

Engineering:
EngCo Inc.
 CA 8116
 6971 W. Sunrise Blvd. 104
 Plantation, FL 33313
 ENGCO@AOL.COM

MAR 23 2009
 Engineer Seal
 Pedro De Figueiredo
 PE 52609

DRAFTING:
PK DRAFTING & MORE

MIAMI-DADE BCCO:

Date: 03/23/2009
 Scale: NA
 Design by: PPMF

Drawing Number
09-058

SHEET
 9 of 9